

Contributions to the design and construction of characteristic curve tracers for photovoltaic devices

E.F. Fernández, J. Montes-Romero, J. de la Casa
IDEA Research Group, University of Jaén,
Campus Lagunillas, 23071 Jaén, Spain
E.F. Fernández: fenandez@ujaen.es

A. Firman, M. Cáceres, L.H. Vera
GER – Grupo en Energías Renovables - FaCENA – UNNE,
Av. Libertad 5470 – 3400 Corrientes. Argentina

Abstract— Tracing the characteristic I - V curve of any photovoltaic device is the essential experiment that allows us to obtain reliable information about its state and behavior. Therefore, it must be part of the practical content in any Bachelor's, Master's or PhD degree that teaches the students in the photovoltaic systems engineering field. This paper presents the progress-achievements of two research groups -from Argentina and Spain- in the design of electronic prototypes or ad-hoc systems that carried out this experiment and which have subsequently been integrated into teaching practices. In addition, this knowledge has been incorporated into the research area in which the groups are involved.

Keywords— Photovoltaic systems engineering; electronic charges; Photovoltaic devices characterization, renewable energies teaching.

I. INTRODUCTION

Photovoltaic (PV) electrical generation has been a great success recently in the renewable energies field. As an example, during the period 2005-2015, an annual growth rate of 27 % of investment in PV technology was registered [1]. Besides, during 2016, 75 GWp has been installed in the world [2]. In late 2017, there was a surplus of 320 GWp of global installed power [3]. Currently, countries like China, Japan, USA and Germany are leading the amount of installed PV power, but there are reasons to think that this amount will continue growing around the world, especially in emerging countries due to the need of increasing their electric generation for their development.

Promoting and training qualified personal who lead this emerging market is considered of great importance. To achieve this goal, it is essential to include this topic in engineering studies [4].

There is a direct relationship between the electric and electronic engineering area, and the photovoltaic technology. As an example, the 1st generation of crystalline silicon PV cell is based on a PN junction. In addition, a big part of the equipment required to be used in PV systems (such as inverters, charge regulators, characterization devices, etc.) are widely studied in any degree related with electronic engineering.

To understand the PV technology, it is essential to know how the PV generator works. The experiment that provides more data about the behavior of any PV device is by tracing its I - V curve. The I - V curve is made up of pairs of points of current and voltage in which -depending on ambient conditions where the device was exposed during the experiment- a PV device can operate. From this set of points it is possible to obtain its main electrical

parameters, as well as to determine any type of abnormalities, defects or malfunction states [5]–[8].

The research groups to which the authors belong have more than a decade of experience developing different architectures and design solutions directly related with that experiment. This equipment have been used in their research work and incorporated in their teaching tasks [9]–[12]. A review of the most outstanding achievements is presented next.

II. THEORETICAL FUNDAMENTS OF I - V CURVE TRACING

Figure 1 shows a typical I - V curve of a PV device. This characteristic curve is composed by current and voltage points obtained in working conditions when its output impedance varies from zero to infinite. Figure 1 also shows the points of main interest, generally given by manufacturers in their datasheets. Three principal locations can be distinguished: the short circuit current (I_{sc}), the open circuit voltage (V_{oc}) and the point of maximum power (P_m), this last one defined by the maximum voltage (V_m) and the maximum current (I_m).

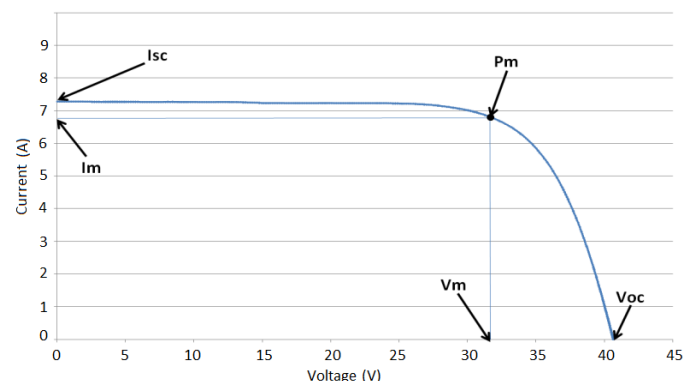

Figure 1. I - V characteristic curve of a PV module and highlighted mains points.

Besides of these electrical values that can be obtained directly from the I - V curve, other important parameters can be obtained by adjusting these set of points by mathematical models [13], which adjust an equivalent electrical model of a cell, a module or of a PV generator. These parameters will be - in the case of the five parameters electrical model- the photogenerated current (I_{ph}), the diode inverse saturation current (I_0), the diode ideality factor (m), the series resistance (R_s) and the shunt resistance (R_{sh}) [14]–[17].

All electrical parameters obtained during the I - V curve tracing are depending on the PV device technology and the operations conditions. Evidently, the most influential parameter

is the plane incident irradiance. This parameter is almost directly proportional to the obtained current. In a second order of magnitude, the cell temperature that affects, like in any semiconductor, the voltage value.

The PV module manufacturers provide the basic electrical parameters values under specific ambient conditions known as Standard Test Conditions (STC), these are defined in the standard IEC 60891 [18] and these are: irradiance of 1000 W/m², cell temperature of 25°C and solar spectrum AM 1.5.

Finding natural conditions similar to those defined in the STC can be extremely complicated. For this reason, there are extrapolation methods to STC [19]–[21]. In this sense, there is a normalized procedure to perform a translation from an IV curve in the standard IEC 60904 [22]. These methods have been of interest in teaching articles intended for students of PV solar energy [23].

In order to achieve the characteristic *I-V* curve tracing, a common basic electronic laboratory equipment is necessary. Roughly, a curve *I-V* tracer is an electronic system able to produce an impedance variation between zero and infinite, thereby it makes a sweep in all the PV element range of work when it is polarized. Besides, for the reason exposed previously, the system must register quasi-simultaneously the ambient parameters at the moment of the test, mainly the irradiance and cell temperature. As its continuous measuring under the entire time test is not always possible, it can be determined at the beginning and at the end of the process only, and finally, check if the value have not changed significantly during the testing time to validate the experiment.

Although it is not one of the main objectives of this paper, for the irradiance measurement two main options can be found. One option is measuring by piranometers and the other is to measure by reference PV cells or reference PV modules [24]. If the reference PV device was constructed with the same materials as the device under test, and it is deployed coplanarly, this device will respond, angular and spectrally, in the same way as the device under test. It leads to neglecting spectral changes if these devices are calibrated under the reference spectrum AM 1.5.

In order to measure the cell temperature, it is indicated that its value is approximately the same when the measurement is done at the back of the PV module. The most used sensor to achieve this measurement is by a platinum resistance (PT100) coupled in the back of the PV module as is recommended in the IEC 61724-1 annex B [25]. Performing the measurement in four-wire configuration is also suggested to avoid voltage drop in the conductors and improve the accuracy.

As is obvious, the market offers equipment destined for IV curve tracing. This equipment presents the advantages of any commercial device: they have been tested and characterized by the manufacturer, but they often have a high price and it can be prohibitive for certain research groups or for dedicated teaching laboratories. Another inconvenience is that commercial products usually include exclusive sensors for irradiance and

temperature measurement, which can be difficult to replace for other types if required. The algorithms of data treatment or translation to STC are closed and they cannot be accessed. In addition, they usually do not include detailed information about the measure uncertainties or the data treatment processes [26]–[28]. Summarizing, commercial equipment is usually created for professional use.

Any IV curve tracing system can be divided in a basic block diagram as is shown in Figure 2. In that figure, three main blocks can be distinguished: impedance variation block, measurement block and control block.

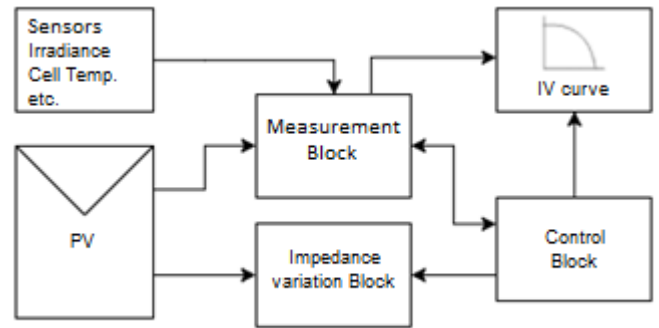

Figure 2. Basic block diagram of any *I-V*.

III. IMPEDANCE VARIATION BLOCK

The impedance variation block is responsible for performing the entire *I-V* curve sweep of PV module varying its polarization point. For this purpose, different types of procedures – summarized in [27] - can be distinguished. The type of procedure should be chosen and designed in function of the PV device electrical characteristics, and the available equipment and materials. The possible methods are: variable resistors, four quadrant power sources, DC/DC converters, active loads and capacitive loads.

The simplest method is using variable resistors. The impedance has to be modified manually, so the operation point can be chosen at each time. The main inconvenience of this method is the power dissipation. The resistor must dissipate all the energy generated by the PV device in each moment. This can be an interesting solution for teaching purposes if low power modules are used, and therefore, the heating problems of dissipation can be neglected. An automation of this method can be hard to carry out.

Another method is using commercial four quadrants power sources like, for example, those offered by Kepco [29]. This device can adjust the PV module operation point to a determined voltage in any of the four quadrants -being especially useful the first, but also the second and the fourth quadrant- and, performing like current sink, it absorbs the PV energy generated. The objective of polarizing from negative voltages to positive currents is to determine with accuracy *V_{oc}* and *I_{sc}* points when the axes crossing occurs. For example, for

Is_c point, it can be difficult to obtain due to series resistances of other elements (wiring, switchers, contacts, shunts, etc). In this way the points can be perfectly determined. At first, this method can seem a simpler solution, however this type of power sources are devices of very high cost, with limited voltages and current ranges, and they have an important size that hinders their transport, relegating them to be used in laboratories. In this aspect, being able to adjust the PV device operation point is interesting for teaching purposes.

The combined experience of the research groups in that type of system is based in [30], where a four quadrant source to control the PV module operation point was used in an entire characterization system at the University of Málaga, as is shown in the Figure 3.

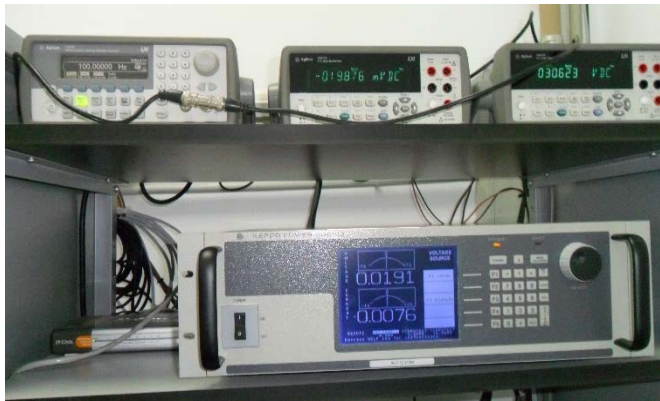

Figure 3. *I-V* curve tracer system based on a four-quadrant power source installed at the University of Málaga.

DC/DC converters are another possible solution to achieve *I-V* curve sweep. These converters have the possibility of changing its impedance depending on its duty cycle. This feature makes it appropriate to solve the sweep problem. A simplified schematic of a power stage of this type of converter is shown in the Figure 4. The main issue of that type of system is the management and dissipation of the energy generated by the PV device during the test. In order to be able to handle a greater amount of power, it is necessary to make series or parallel converters associations. This can be an advantage because it becomes a modular system. Nevertheless, special design strategies are required to avoid excessive ripple in the *IV* curve obtained.



Figura 4. Simplified diagram of the power stage by DC/DC converters.

This type of load has been used for the research groups in bachelor thesis and it was published in [31]. In this system, four SEPIC (Single-ended primary-inductor converter) type

converters were used, allowing *I-V* curve tracing up to $V_{oc} = 400$ V and $I_{sc} = 10$ A, achieving 400 W of dissipated direct power. One of the development systems can be seen in Figure 5.

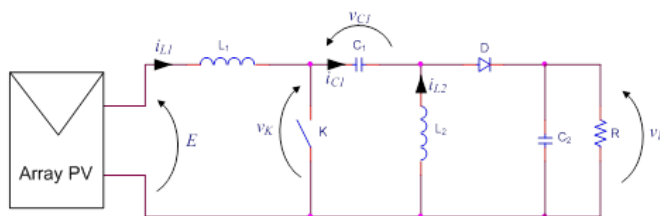
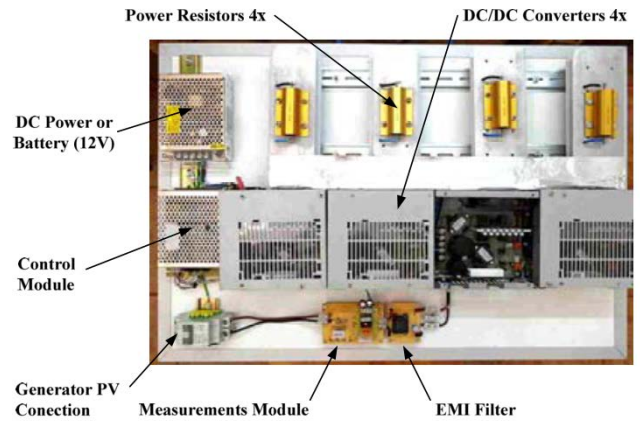

Figure 5. *I-V* curve tracer system based on DC/DC converters.

A relevant feature of the four quadrant power sources and the DC/DC converters is that the *I-V* curve sweep can be done in both directions. It is possible to trace from the point of I_{sc} to V_{oc} or backwards.

Performing the impedance variation through active type loads is also possible. Their operation is based on the work of transistors in active zone. To change its impedance, the working operation zone is changed from the saturation stage to short circuit stage, producing a variation in the PV module operation point from V_{oc} to I_{sc} . The transistors used must be able to dissipate the entire power generated during the *I-V* curve tracing, thus, the active load must have the necessary heat dissipation capacity. To solve this problem, parallel associations are done to increase that capacity. Even so, the maximum permitted junction temperature of these components cannot be exceeded. For that reason, it is advisable to use high sweep rates. One of the possible designs with an active load is shown in Figure 6.

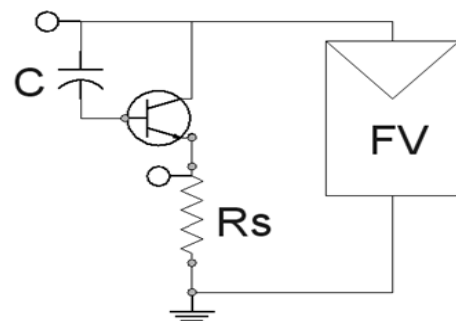

Figure 6. Simplified diagram of a power stage by active load with bipolar transistor.

As experience of the research groups, active loads based in bipolar transistors have been used to achieve the impedance

variation and the consequent power dissipation from the PV device [10]. A prototype of that system is shown in Figure 7.

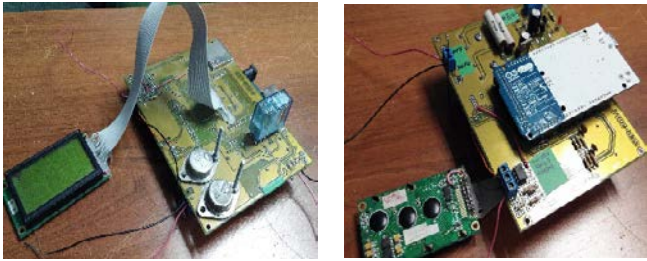

Figure 7. I-V curve tracer system based on active load by bipolar transistor installed at the Universidad Nacional del Nordeste.

Finally, the capacitive loads are another way to perform the I-V curve tracing. Its operation is based in a capacitive charge transient. For this, a completely discharged capacitor (or a bank of them) will start its charge process from zero impedance up to infinite when its charge is complete. During the charge process, the PV module varies its operation point completely. The voltage and current curves of this process can be seen in Figure 8.

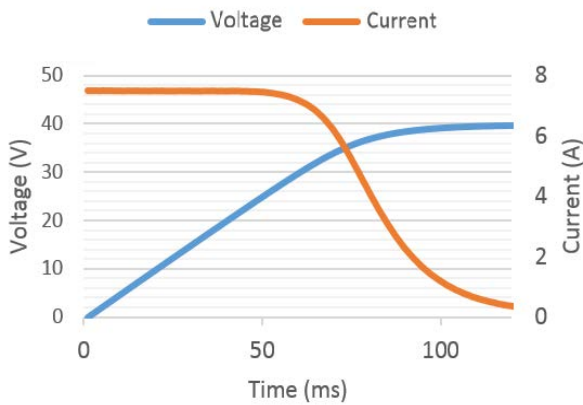

Figure 8. Voltage and current waveform in the capacitor charge process.

The main advantages of that type of load are the simplicity and there is no power dissipation during the tracing. The PV module generated energy is stored in the capacitor bank, which later will be discharged onto a power resistance in a completely controlled process. As a main disadvantage, this process does not permit the PV module polarization on a determined point. Besides, due to the waveform presented for the capacitor, the measures will be gradually more grouped as they approach to V_{oc} , as Figure 8 shows.

The research groups have developed a wide experience in the design and implementation of systems using this method [9], [12], [32]. Due to the simplicity and the low cost of that type of charges, several models of I-V curve tracers based on this methodology have been made over the last few years, and

it is the most common method at present in the research groups. Figure 9 shows a picture of one of the systems developed.



Figure 9. I-V curve tracer system based on a capacitive load and installed at the University of Jaén.

IV. MEASUREMENT BLOCK

The measurement block will be responsible for acquiring-conditioning the voltage-intensity values simultaneously. In addition, this block will obtain the relevant environmental parameters present at the time of the experiment.

In Figure 10, a simplified connection diagram to perform the measurement of the voltage-current pairs is presented.

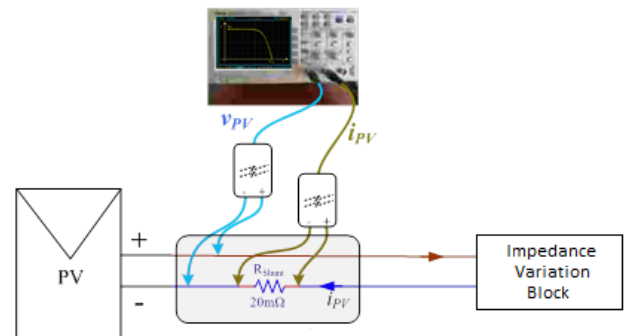

Figure 10. General schematic of the connections to perform the measurements of the PV device.

The measurement simultaneity of the voltage and current parameters is essential, so it is necessary to ensure that the measured pairs coincide with the same time base.

In most cases, the measurement of the current is done indirectly. For this purpose, the current measurement can be obtained by the voltage drop on a shunt resistor. Also, a Hall effect sensor can be used. This kind of sensor has the advantage of not requiring a physical connection with the circuit, but a drift in the measurement -which is complicated to quantify- has been reported. The voltage measurement -in most cases and

using commercial equipment- is done directly. Otherwise, a signal treatment must be done by a voltage divider circuit.

The simplest solution to perform the measurements is by the use of commercial oscilloscopes. A two-channel oscilloscope can perform the measurement of voltage and current of any PV module simultaneously. A better solution is using a four-channel instrument with isolated channels. This permits the measurement of the I-V pairs and the measurement of two basic ambient sensors.

The main advantages of using oscilloscopes to perform the measurements are the simplicity of its use, high sampling rate and the synchronization of the current and voltage measurements.

When using commercial multimeters, they must be able to allow synchronization through an external trigger, ensuring the measurements are performed simultaneously. Most of them can also perform resistance measurements, allowing the use of temperature resistive sensors directly.

The main advantage of these instruments is the high precision. As disadvantage –due to the need of two instruments- the rise in the final cost of the system, but the development of these instruments through software such as LabVIEW can be a very formative practice of any student.

Without dispose commercial equipment, electronic systems based, for example, on open-source hardware platforms can be used. The choice of the electronic components must satisfy the conditions exposed previously. The elaboration of an ad-hoc measurement system can be complex but it can be carried out by a specialized engineer.

As expected, not using commercial equipment will reduce substantially the budget of the system. The complexity of the design of a complete system and the difficulty of ensuring the measurement quality are the main obstacles of this kind of system.

For the measurement task, during the years of experience of the research groups, different kinds of oscilloscopes –two channel, four channel, isolated and common- has been used [31], [33]. In addition, a pair of commercial multimeters –one for voltage and another for current- has been used to measure the I-V curve [11], [12], [32]. Electronic measurement circuits have been also designed and developed, adapted to the specific needs of the PV systems.

V. CONTROL BLOCK

As stated in previous sections, once the impedance variation problem is solved with any kind of load, the measurements of current and voltage of the PV module can be taken together with the irradiance and temperature data. All the process is governed by the control block. This block can be a microcontroller device, a datalogger with digital inputs and outputs, a function generator, manual or automatic switches, etc. A control

software, employed to sequence the process, manages all the components of the system, depending on the selected load.

In case of the four-quadrant power supplies, the control is performed directly, usually, through a PC. As is normal in commercial equipment, the control varies depending on the manufacturer. As a common characteristic, the control can be programmed by software. Therefore, to perform the I-V sweep only a PC with the software is necessary.

The control of the DC/DC converters is carried out by pulse trains: square wave to activate the converters and triangular wave of voltage reference to vary the impedance of the converter. The simplest method to generate these signals is by the use of a signal generator. These instruments ensure the quality of the control signals. A more complex solution is to design the electronic circuit necessary to generate the signals. A possible schematic of this system is presented in Figure 11.

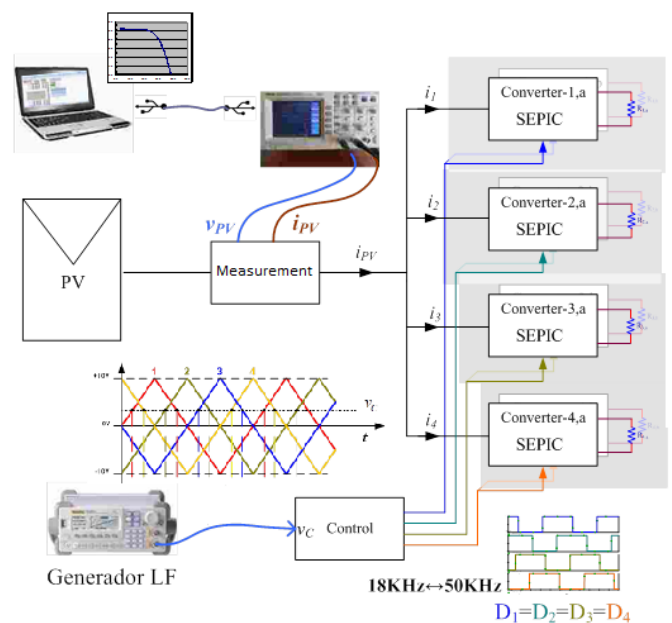

Figure 11. General schematic of a I-V tracing system by the use of DC/DC converters.

The control of active loads is different depending on the technology of the transistor. In the case of bipolar transistors, the control can be done by the current on the base of the transistor. As exposed in [10], the control is done automatically as function of the β parameter of the transistor through the charge of a control capacitor. The sweeping time of the I-V curve is governed by the equation (1). For transistors controlled by voltage on the gate (MOSFET and IGBT), the control can be done varying the voltage on an increasing or decreasing function such as sine wave, triangular wave, etc.

$$t = \frac{V_{oc}^2 \cdot C \cdot \beta}{P_m} \quad (1)$$

Switches carry out the control of a capacitive load. The charge and discharge processes are highlighted. By closing the

charge switch SW1 (Figure 12), the process is started. It will stop when the capacitor is completely charged (capacitor voltage and V_{oc} of the PV module are equal). Then, SW1 is opened and the discharge switch SW2 closed. The discharge process will start and the resistor will consume the stored energy in the capacitor. It must be taken into account that the switches must allow the voltage and current provided by the PV module. The dissipated power by these switches will be minimum, but they must allow the PV characteristics. In order to control the process, a wide variety of elements can be used as switches: any technology of transistors (BJT, MOSFET, IGBT), thyristors, solid state relays, electro mechanic relays, etc.

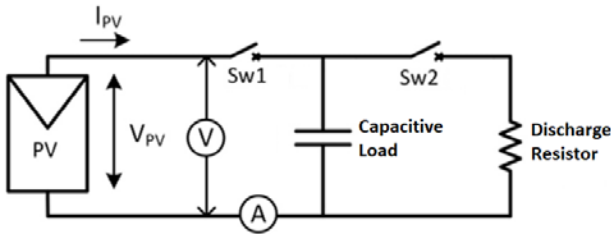

Figure 12. Simplified schematic of a power stage for a capacitive load.

The charging time of the capacitor can be estimated through the equation (2). It will be necessary to consider parameters of the PV generator such as V_{oc} and P_m . It also depends on the capacity of the capacitor.

$$t = \frac{V_{oc}^2 \cdot C}{P_m} \quad (2)$$

Among the control elements used by the research groups, Arduino boards, TIVA boards, NI-DAQ systems, dataloggers, parallel ports controlled by PC, manual switches, PIC microcontrollers, function generators, etc. can be highlighted.

Those systems can generate the necessary control signals to trace the $I-V$ curve. As connection switches for capacitive loads, MOSFET and IGBT transistors, thyristors and solid state relays were used to develop those systems. As control software programming languages such as C, Visual Studio or LabVIEW, must be highlighted.

VI. CONCLUSIONS

This article presents descriptively the most relevant aspects of the design and construction of $I-V$ curve tracers applied in photovoltaic technology.

Probably, the most important conclusion is the relative ease to incorporate this experiment in any subject related with PV technology with a basic electronic laboratory.

In addition, as is the case of the authors, those subjects are integrated in the electronic engineering or telecommunications degrees. In this case, the design, construction and programming of each block is highly formative for the students. It helps to consolidate and apply knowledge of main subjects in the area

(Analog, Digital and Power electronics, Instrumentation, Data Acquisition Systems, etc). It is also considered an option as a bachelor or master thesis because of the integration of different knowledge related to the specialty and applied to a specific case.

Different methods to perform the $I-V$ curve trace process have been presented. In order to guide the reader and simplify the process, three blocks have been highlighted: impedance variation, measurement and control.

Undoubtedly, the most important and complex part of the instruments employed to trace the $I-V$ curve is the variable load that sweep the whole impedance range. All the different kinds of loads designed and developed by the research groups of the authors have been described and referred. Furthermore, the main parameters that must be considered in the design and implementation of this kind of system has been exposed. Also, references explaining in detail the developed systems have been included.

In this way, this article aims to support the teaching of photovoltaic solar energy through the implementation of $I-V$ curve trace systems with teaching and researching purposes. This kind of equipment can be used for both undergraduate and graduate levels.

REFERENCES

- [1] Bloomberg New Energy Finance, "Global Trends in Clean Energy Investment," 2017.
- [2] SolarPower Europe, "Global market outlook for solar power 2017-2021," 2017.
- [3] Fraunhofer Institute for Solar Energy Systems, "Photovoltaics Report," 2017.
- [4] J. De Casa, M. Fuentes, J. V Muñoz, D. L. Talavera, G. Nofuentes, and J. Aguilera, "Herramientas para la docencia de créditos prácticos en asignaturas directamente relacionadas con la energía solar fotovoltaica .," in *TAEE 2012*, 2012, pp. 168–173.
- [5] M. García, J. M. Maruri, L. Marroyo, E. Lorenzo, and M. Pérez, "Partial Shadowing, MPPT Performance and Inverter Configurations: Observations at Tracking PV Plants," *Prog. Photovolt Res. Appl.*, vol. 15, no. April, pp. 659–676, 2008.
- [6] D. Picault, B. Raison, S. Bacha, J. de la Casa, and J. Aguilera, "Forecasting photovoltaic array power production subject to mismatch losses," *Sol. Energy*, vol. 84, no. 7, pp. 1301–1309, 2010.
- [7] M. Piliouguine, C. Cañete, R. Moreno, J. Carretero, J. Hirose, S. Ogawa, and M. Sidrach-de-Cardona, "Comparative analysis of energy produced by photovoltaic modules with anti-soiling coated surface in arid climates," *Appl. Energy*, vol. 112, pp. 626–634, 2013.
- [8] A. Firman, V. Toranzos, A. Busso, L. Vera, and J. de la Casa, "Qualitative analysis of electrical mismatch losses in photovoltaic devices," in *EUPVSEC*, 2013, pp. 3212–3215.
- [9] C. Bello, V. Jimenez, V. Toranzos, A. Busso, L. H. Vera, and C. Cadena, "RELEVADOR PORTATIL DE CURVAS I-V DE PANELES FOTOVOLTAICOS COMO HERRAMIENTA DE DIAGNOSTICO IN SITU DE SISTEMAS DE GENERACION FOTOVOLTAICA," *Av. en Energías Renov. y Medio Ambient.*, vol. 13, pp. 77–83, 2009.
- [10] A. Firman, V. Toranzos, A. Busso, C. Cadena, and L. Vera, "Sistema híbrido para la caracterización eléctrica de arreglos fotovoltaicos," *Av. en Energías Renov. y Medio Ambient.*, vol. 14, pp. 17–23, 2010.
- [11] J. V. Muñoz, J. de la Casa, M. Fuentes, J. Aguilera, and J. C. Bertolín, "New portable capacitive load able to measure PV modules, PV strings and large PV generators," in *26th European Photovoltaic Solar Energy Conference and Exhibition*, 2011, vol. 1, pp. 4276–4280.

- [12] J. Montes-Romero, M. Piliouguine, J. Muñoz, E. Fernández, and J. de la Casa, "Photovoltaic Device Performance Evaluation Using an Open-Hardware System and Standard Calibrated Laboratory Instruments," *Energies*, vol. 10, no. 11, p. 1869, 2017.
- [13] A. M. Humada, M. Hojabri, S. Mekhilef, and H. M. Hamada, "Solar cell parameters extraction based on single and double-diode models: A review," *Renew. Sustain. Energy Rev.*, vol. 56, pp. 494–509, 2016.
- [14] M. A. De Blas, J. L. Torres, E. Prieto, and A. García, "Selecting a suitable model for characterizing photovoltaic devices," *Renew. Energy*, vol. 25, no. 3, pp. 371–380, 2002.
- [15] J. C. H. Phang, D. S. H. Chan, and J. R. Phillips, "Accurate analytical method for the extraction of solar cell model parameters," *Electron. Lett.*, vol. 20, no. 10, p. 406, 1984.
- [16] E. F. Fernández, J. Montes-Romero, J. de la Casa, P. Rodrigo, and F. Almonacid, "Comparative study of methods for the extraction of concentrator photovoltaic module parameters," *Sol. Energy*, vol. 137, pp. 413–423, 2016.
- [17] J. Montes-Romero, F. Almonacid, M. Theristis, J. de la Casa, G. E. Georghiou, and E. F. Fernández, "Comparative analysis of parameter extraction techniques for the electrical characterization of multi-junction CPV and m-Si technologies," *Sol. Energy*, vol. 160, no. December 2017, pp. 275–288, 2018.
- [18] International Electrotechnical Commission, "IEC 60891, Photovoltaic Devices. Procedures for Temperature and Irradiance Corrections to Measure I-V Characteristics," Geneva, Switzerland, 2007.
- [19] G. . Araujo and E. Sánchez, "Analytical expressions for the determination of the maximum power point and the fill factor of a solar cell," *Sol. Cells*, vol. 5, pp. 377–386, 1982.
- [20] K. Emery and C. Osterwald, "Measurement of photovoltaic device current as a function of voltage, temperature, intensity and spectrum," *Sol. Cells*, vol. 21, no. 1–4, pp. 313–327, Jun. 1987.
- [21] A. Firman, V. Toranzos, A. Busso, C. Cadena, and L. Vera, "Determinación del punto de trabajo de sistemas fotovoltaicos conectados a red: metodo simplificado de traslacion punto a punto a condiciones estandar de medida," *Av. en Energías Renov. y Medio Ambient.*, vol. 15, pp. 1–8, 2011.
- [22] International Electrotechnical Commission, "IEC 60904-1, Photovoltaic Devices, Part 1: Measurement of Photovoltaic Current–Voltage Characteristics," Geneva, Switzerland, 2006.
- [23] J. Montes-Romero, M. Torres-Ramírez, J. De La Casa, A. Firman, and M. Cáceres, "Software tool for the extrapolation to Standard Test Conditions (STC) from experimental curves of photovoltaic modules," in *Proceedings of 2016 Technologies Applied to Electronics Teaching, TAAE 2016*, 2016.
- [24] A. Firman, L. Zini, R. Sanchez, and L. Vera, "Desarrollo y calibración de dispositivos fotovoltaicos para determinar el recurso solar utilizable por sfcr," *Av. en Energías Renov. y Medio Ambient.*, vol. 18, pp. 9–17, 2014.
- [25] International Electrotechnical Commission, "IEC 61724-1: Photovoltaic system performance - Part 1: Monitoring," 2017.
- [26] P. C. Neuenstein J., "Los módulos y sus curvas," *Photon. La Rev. fotovoltaica*, pp. 54–71, 2009.
- [27] P. Hernday, "Field Applications for I-V Curve Tracers," *SolarPro*, no. August/September, pp. 76–106, 2011.
- [28] Tritec, "Operating Instructions Tri-ka," 2010.
- [29] Kepco Inc., "http://www.kepcopower.com/." .
- [30] M. Piliouguine, J. Carretero, L. Mora-López, and M. Sidrach-De-Cardona, "Experimental system for current-voltage curve measurement of photovoltaic modules under outdoor conditions," *Prog. Photovoltaics Res. Appl.*, vol. 19, no. 5, pp. 591–602, Aug. 2011.
- [31] J. C. Bertolín, M. Fuentes, J. V. Muñoz, and J. de la Casa, "Applications of DC/DC converters for obtaining characteristic curves of PV generators," in *27th European Photovoltaic Solar Energy Conference*, 2012.
- [32] J. V. Muñoz, M. Torres-Ramírez, B. García-Domingo, M. Fuentes, J. de la Casa, G. Nofuentes, and J. Aguilera, "Automatic monitoring system to assess the outdoor behaviour of photovoltaic modules," in *29th European Photovoltaic Solar Energy Conference and Exhibition*, 2014, pp. 2654–2657.
- [33] G. Nofuentes, J. Aguilera, E. Álvarez, L. Hontoria, and J. de la Casa, "Estimación de la potencia máxima media en condiciones estándares de medida de un módulo fotovoltaico de silicio cristalino," in *X Simposio Peruano de Energía Solar*, 2003.